

frame light barrier

type: LAG M40



picture alike

LAG M40

5101 92xx

Sep-21

- very small type
- high sensitivity
- insensitive to external effect of light
- external amplifier with adjustable pulse length and sensitivity
- dirt accumulation compensation with indicator
- scratch-resistant optic
- oil-resistant PUR-cable

application range

part output detection

quick process counting

technical data

feature	
voltage supply	12 .. 32 V DC
max. current	dependent on type 200 mA
transmitter	IR-LED
receiver	photo transistor
housing	alu, gold anodised
outputs	dynamic*
output pulse with	adjustable, 5 levels 20, 50, 100, 200 300 ms
output level	Ub (max. 50mA)
sensitivity dynamic	0.2 mm (ball)
sensitivity	adjustable, 5 levels
switching frequency	1 kHz
switching state indicator	LED red/green/yellow (dirt indicator)

subject to change

TRsystems GmbH, system area
 UNIDOR
 Freiburger Straße 3
 75179 Pforzheim
 Tel. +49 (0) 7231 3152-0
 unidor@trsystems.de
www.unidor.de

frame light barrier

type: LAG M40

LAG M40

5101 92xx

Sep-21

ambient conditions

operating temperature range	-20 .. + 60°C
enclosure rating	IP 67
ambient light level	5000 Lux
resistant against chem. substances	Connecting cables resistant to oil

* output high-signal at free light beam

order data / types

type	description	order number
LAG-M40/10	cable length 1m	5101 9255
LAG-M40/15	cable length 1m	5101 9256
LAG-M40/20	cable length 1m	5101 9257
LAG-M40/25	cable length 1m	5101 9258
LAG-M40/30	cable length 1m	5101 9259
LAG-M40/40	cable length 1m	5101 9260
LAG-M40/50	cable length 1m	5101 9261
LAG-M40 50/50	cable length 1m	5101 9560
FLB-CON 1-Q	amplifier	5101 9251
LAG-CON 1	connecting cable 2m open ends	5101 9252
CCB LAG-M V*WZS (4B/7S)	connecting cable 2m FLB CON/WZS 7pol.	6410 4008 0020
M12 plug	4-pin own manufacture	6200 0627
M8 plug	3-pin own manufacture	62000 1569

dimensions

type	measure A
LAG-M40/10	10 mm
LAG-M40/15	15 mm
LAG-M40/20	20 mm
LAG-M40/25	25 mm
LAG-M40/30	30 mm
LAG-M40/40	40 mm
LAG-M40/50	50 mm
LAG-M40 50/50	50 mm

subject to change

TRsystems GmbH, system area
 UNIDOR
 Freiburger Straße 3
 75179 Pforzheim
 Tel. +49 (0) 7231 3152-0
 unidor@trsystems.de
www.unidor.de

frame light barrier

type: LAG M40

LAG M40

5101 92xx

Sep-21

dimensions

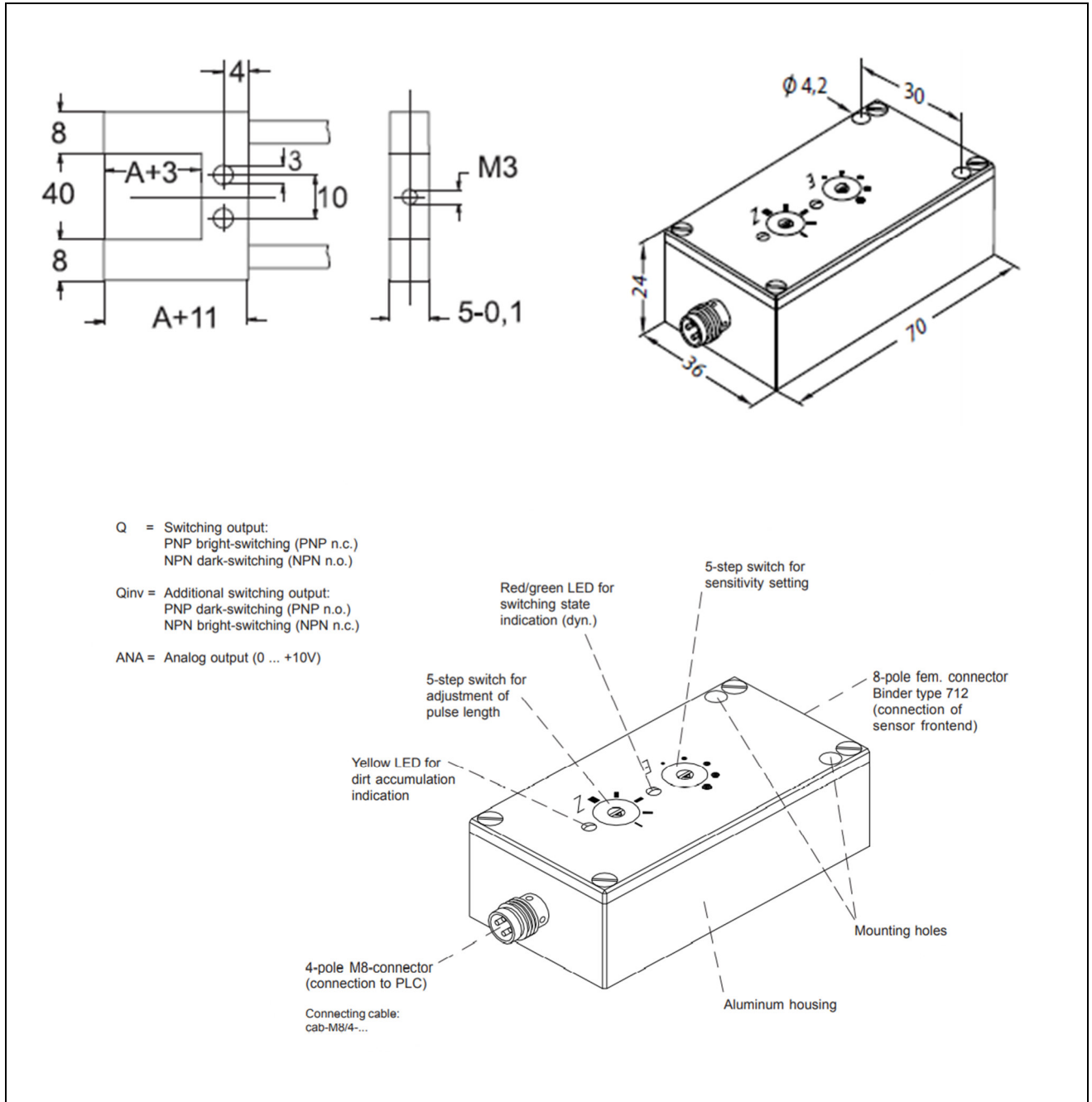

subject to change

TRsystems GmbH, system area
UNIDOR
Freiburger Straße 3
75179 Pforzheim
Tel. +49 (0) 7231 3152-0
unidor@trsystems.de
www.unidor.de

frame light barrier

type: LAG M40

LAG M40

5101 92xx

Sep-21

pin assignment

M16, 7pin (6410 4008 0020)

colour	Pin	operation
-	1	n.c.
-	2	jumper to 3
-	3	jumper to 2
white or yellow	4	signal
green and shield	5	GND 0V
brown	6	UB
-	7	n.c.

M12, 4pin (6200 0627)

colour	Pin	operation
brown	1	UB
-	2	n.c.
green and shield	3	GND 0V
white or yellow	4	signal

M8, 3pin (62000 1569)

colour	Pin	operation
brown	1	UB
white or yellow	4	signal
green and shield	3	GND 0V

subject to change

TRsystems GmbH, system area

UNIDOR

Freiburger Straße 3

75179 Pforzheim

Tel. +49 (0) 7231 3152-0

unidor@trsystems.de

www.unidor.de